

ELECTRIC CHAIN HOIST

DMK series, the most reliable and safe way to lift

The DMK electric chain hoists respond to the needs of the international markets which require products of guaranteed quality with a wide range of uses, long-term reliability, safety guarantees in all phases of operation, and excellent value for money. The DMK hoists stand out for their careful and modern design putting them at the top of their category. The quality of the components, the high technology used in the production of the mechanical parts, in the finishes and in the surface treatments, the constant and checked quality system UNI EN ISO 9001 which covers the company's entire production, allow DONATI SOLLEVAMENTI to offer a product in line with the latest international standards.

The special water-repellent paintwork is applied with an electrostatic process in complete isolation which guarantees its durability and a constant high performance, also in particularly hostile environments.

The DMK electric chain hoists are part of the lifting products range manufactured by DONATI SOLLEVAMENTI, a leading

company in its field in Italy, and one of the leading

companies in the world in the lifting equipment sector. The warranty lasts 3 years from the delivery date.



DONATI SOLLEVAMENTI S.r.l

presents its advanced and innovative electric chain hoists.

The DMK hoists are safe, reliable, compact and economical, and represent a modern solution perfectly suited to the needs of the worldwide market for lifting loads up to 4000 kg.



electric chain hoist



and trolleys

power and safety



at your disposal

power and safety at your disposal

THE ELECTRIC CHAIN HOIST AND TROLLEYS

The electric chain hoist is a machine generally used to lift an unguided load by means of a hook or handling accessories suitable for the purpose.

The hoist combined with an electric or manual trolley, which run on beam, ensures the integrated handling of lifting and horizontal movements of the load.

The electric chain hoist and the trolleys can be fitted on a beam (monorails) or can constitute the lifting unit of other

machines in which they have been incorporated, such as: jib crane, overhead travelling crane, etc.

The electric chain hoist, positioned on a beam or at ground-level, can be used in different configurations in a fixed position.

The range of DMK electric chain hoists series is produced in:

- **4 basic sizes:** DMK 1 - 2 - 3 - 4, to lift loads from 100 to 4.000 kg, available as standard executions, in the FEM (ISO) service units - 1Bm (M3) 1Am (M4) - 2m (M5).
- **with one lifting speed** made with a 1 polarity motor:
 - 4 or 6,3; 8; 16 m/min for 1 chain fall hoists
 - 2,5 or 3,2; 4 m/min for 2 chain fall hoists
- **with two lifting speeds** made with pole change motor:
 - 4/1, 2 or 8/2,5 m/min for 1 chain fall hoists
 - 2,5/0,8 or 3,2/1 m/min for 2 chain fall hoists
- **standard hook runs:** up to 12 m
 - above 12 m available on request



ELECTRIC CHAIN HOIST

the range of the DMK series

The flexibility of utilization of DMK hoists allows 6 standard configurations.

Fixed configuration: eyebolt suspension as a standard, or hook suspension on request.

Hand-pushed trolley configuration: horizontal movement pushing the load. It is recommended for light duty and short load travel only.

Electrically-operated trolley configuration: this version is recommended when manual load pushing is not feasible, and for heavy duty. The load is moved by the trolley which is controlled by the hoist pushbutton panel.

Manual gear operated chain trolley configuration: the trolley is operated by use of a chain that moves the wheels and is controlled by the operator. This configuration is used in applications accomplishing a low number of cycles, when load travel is short, or when micro inching is required.

Low headroom execution: the hoist, to get the maximum hook-run is fitted on a frame with a return system for the chain, the frame is mounted on 2 trolleys (executions available electric or hand push).

"Climbing" execution: the "climbing" execution allows the reaching of the installation point with the hook and the related chain, without having to lift the entire weight of the hoist. It is particularly suited to the entertainment industry, that is when frequent installation and dismantling of the hoist at greater heights take place.

The DMK electric chain hoists and related electric trolleys are produced according to the design of modular components which, assembled together in relation to commercial needs, as well as the standard versions available in the warehouse, allow various standardized and special executions to be carried out rapidly and economically.

The basic components, motor and reduction gear, thanks to their extreme compactness are assembled together in coaxial line, to ensure maximum use of the hook run and minimum headroom of the hoist body.

The manufacturer uses the most advanced technology based on production processes of high industrialization and allows the realization, by economies of scale, of totally reliable and technically innovative machines.

A high level of quality is guaranteed and checked by the company quality control system according to standard UNI EN ISO 9001: 1994.

Protection and insulation of electrical parts:

- Self braking lifting and travelling motors: Protection IP55 - Insulation class "F"
- Limit switch: Minimum protection IP65 - Maximum insulation voltage 500 V
- Cables: CEI 20/22 II - Maximum insulation voltage 450-750 V
- Protections and insulations different from standard are available on request.

Electrical power supply:

- The DMK electric chain hoists are designed to be powered with alternate current with:
- three-phase voltage of 400 V - 50 Hz. according to IEC 38-1.
- single-phase voltage of 230 V +/- 5% - 50 Hz. (for DMK hoists 1 - 2 - 3, at one speed and capacity up to 800 kg).
- Voltage and frequency different from standard are available on request.

Nominal conditions of use in standard execution:

- Temperature of use: minimum - 10° C; maximum +40° C.
- Maximum relative humidity: 80%
- Maximum altitude 1000 m above sea level.
- The machine must be placed indoors, in a well-ventilated place free of corrosive vapours (acid vapours, saline mist, etc).
- Special executions, for different environmental conditions or for outdoor use are available on request.

Noise

- The level of acoustic pressure emitted by the hoist at full load is always less than a level of 85dB (A). The incidence of environmental characteristics such as sound transmission from the ground through metallic structures, reflections caused by combined machines and walls is not included in the level indicated.



THE HOIST IN DETAILS

1. Reduction gear

Epicyclic crown wheel with heat-treated high-strength steel gearing supported by oil-bath lubricated ball bearings. Noise level at full load is less than 85 db. The aluminium casing is finned externally for more effective heat dissipation by radiation.

2. Self-braking electrical motor

The axial movement of the tapered brake ensures a fast braking action that remains reliable upon time accrual [RES. 4.1.2.1 c - Machinery Directive].

Brake lining is asbestos-free. The motor is available in two versions: a single polarity version for one-speed hoists, and a pole change version for two-speed hoists.

3. Chain

The chain is gauged and made of high-strength steel rod having an ultimate tensile strength of 80 kg/mm², and ultimate elongation higher than 10%.

The applicable safety coefficient is always better than 5 [RES. 4.1.2.4 - Machinery Directive].

The heat and galvanising treatments applied to the chain ensure high resistance to wear, aging and corrosion.

4. Load sprocket

The load sprocket is heat treated, and has five pockets. The pockets are machined by use of precision machinery. The sprocket drives the chain, and ensures optimized chain motion.

5. Chain guide (inserter/extractor)

This component provides for insertion and extraction of the chain links into and from the pockets of the load sprocket, both in ascent and descent. [RES. 4.1.2.6 - Machinery Directive].

6. Load hook

The hook, made of high strength forged steel, is fitted with a safety device [RES. 4.1.2.6 - Machinery Directive], and rotates on a thrust bearing.

7. Single fall bottom block (1 chain fall hoists)

The bottom block is the joining element between the chain and the hook. It is made of steel, and is equipped with a heat-treated large cross-section chain locking pin.

8. Two falls hookblock (2 chain fall hoists)

Made of aluminium, completely closed, it is equipped with a high-resistance steel transmission reel, thermally treated, with pockets for the housing of the chain.

9. Chain stops

The stops are fitted on both the ascending and descending sections of the chain. They act as limit switches of hook travel [RES. 4.1.2.6 a - Machinery Directive], and can be set as desired. They are made of forged steel, and are fitted with a shock-absorbing insert.

Chain box

The chain box is available in several sizes as a function of hook travel. It is made of shock-resistant plastics and is fitted with suspensions which ensure freedom of movement.

10. Clutch device

The clutch is an emergency device that replaces the traditional electrical limit switches as chain full up and down stops. It also operates as an overload protection [RES. 4.2.1.4 - Machinery Directive].

The clutch discs are asbestos-free, and are pre-loaded through a set of Belleville washers.

11. Balancer

The balancer is connected to the clutch joint, and provides for correct hoist balancing. It absorbs the heat generated during clutch operation.

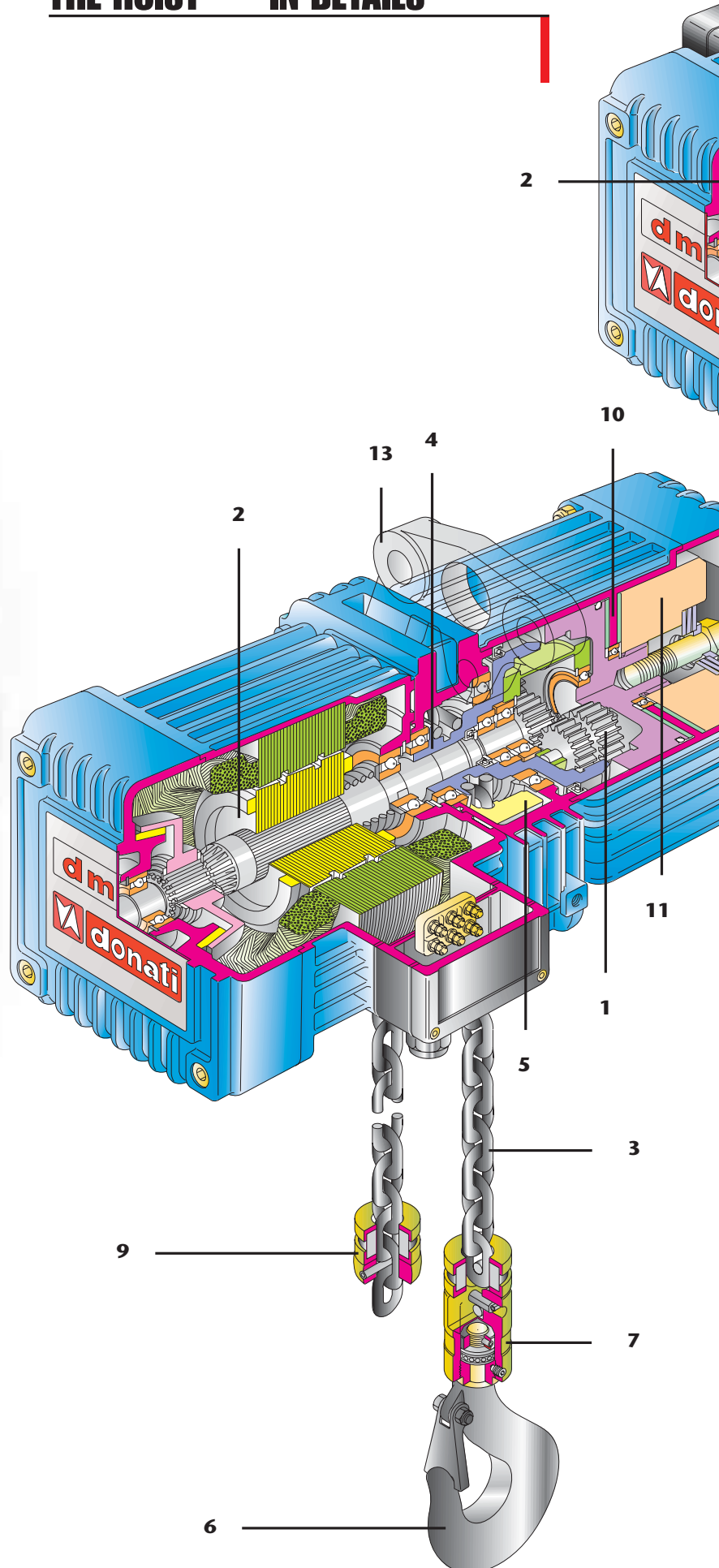

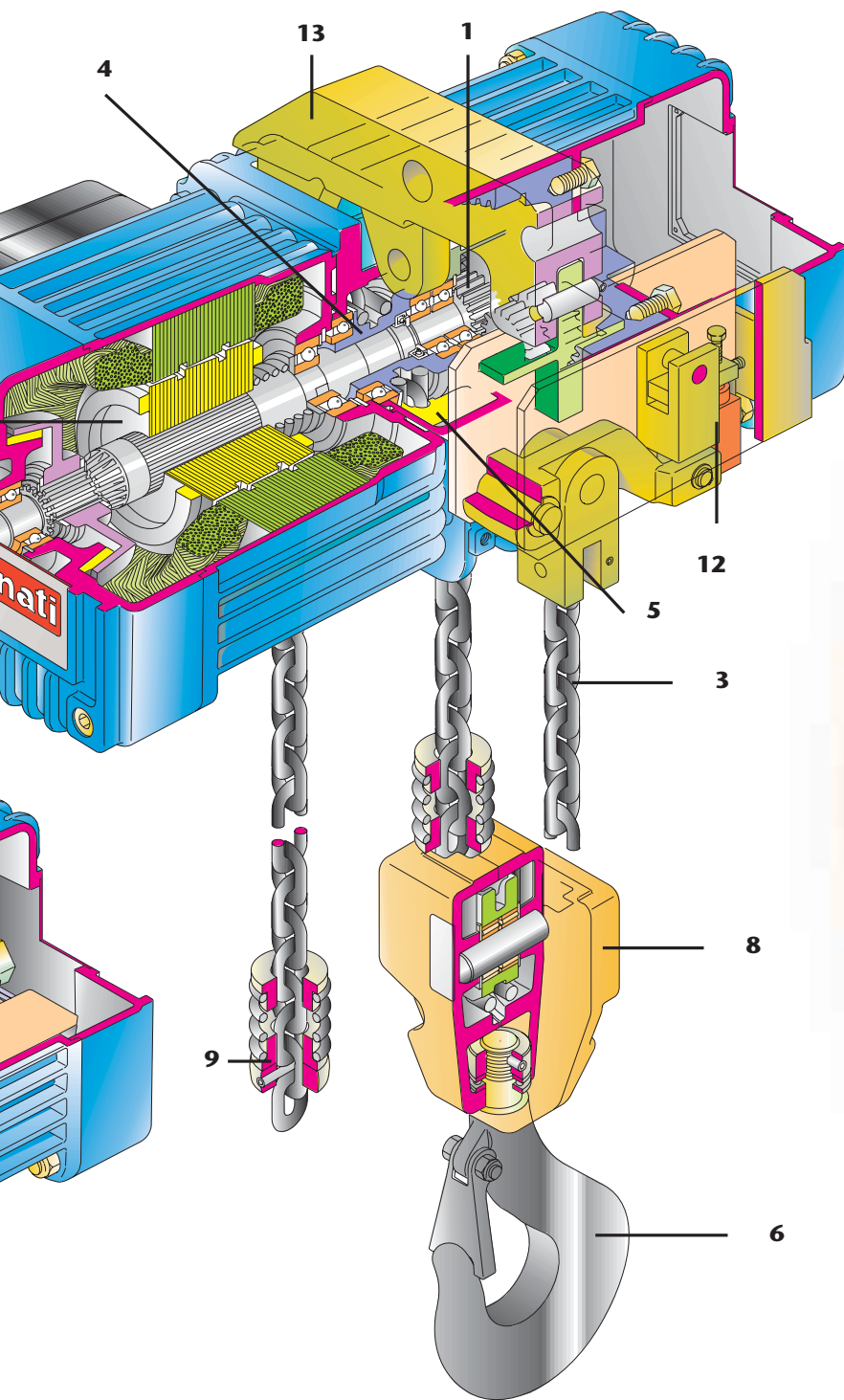

1 chain fall up to 2000 kg

A technical innovative solution which provides:

- reduced headroom and a bigger hook-run as the single fall hookblock is of smaller dimensions than a two falls one, the chain collector is also smaller
- greater safety for the operator who can touch the hook and the chain without danger of being dragged along or crushed
- greater reliability, reduced maintenance and lower working costs because the chain cannot jam, there is not wear by the return and in the lower block there are no moving parts to replace
- greater flexibility of use

2 chain falls up to 4000 kg

A cost-effective solution in terms of the whole system which:

- offers a fixed anchorage point to which an overload device is fixed suited for heavy applications thereby avoiding the need to over dimension the structures of support
- keep the headroom of the hoist and the cost of the chain low.

12. Overload device (2 chain fall hoists)

Electromechanical, with a microswitch for one intervention threshold [RES. 4.2.1.4 - Enclosure I Machinery Directive].

The overload device does not permit the hoist to be loaded with an overload exceeding 20% of its maximum capacity, by blocking the control circuit of the lifting control device.

Lifting limit switches

Included in the supply for the 2 chain fall hoists and available, on request, for 1 chain fall hoists, they limit the hook's ascent and descent run [RES. 4.1.2.6 a) - Enclosure I Machinery Directive]. They are made of two precision microswitches which function according to the principle of "slow positive opening" and work on the auxiliary circuit of the control device of the lifting motor.

13. Suspension

It is produced with an eyebolt suspension; are available on request, the executions with hook suspension or by eyebolt 90° version for longitudinal positioning of the hoist.

Electrical controls

When the hoist is supplied with electrical controls, the movements can be activated, alternatively, by:

- **low voltage controls at AC 48 V – 50 Hz**, including: the transformer for the low voltage power supply of the control circuits, the general line contactor, the contactors for the control of the hoist and trolley motors, the protection fuses of the transformer, the terminal block for the connections of the auxiliary and power circuits. The components are fitted in a box with IP55 protection, made of shockproof thermoplastic material. The equipment is located on the motor side of the hoist.
- **direct control**, directly connected to the power supply, available exclusively for the control of the electric hoist only, raise/lower functions.

It works by means of a power pushbutton panel which interrupts and directly connects the power line.

In both options, the controls are activated by the pushbutton panel, of ergonomic shape, made of self-extinguishing shockproof thermoplastic material, waterproof with IP65 protection.

The emergency stop function [RES. 1.2.4 - Enclosure I Machinery Directive], is produced with a mushroom-head button which using an intentional release action puts the control circuit in the forward position [RES. 1.2.3 - Enclosure I Machinery Directive].

The pushbutton panel is connected to the hoist by a multipolar electrical cable supported by tear proof metallic parts.

DMT trolleys The trolleys are used when loads are to be moved horizontally. They are identified with code DMT, and are available in the following versions:

- **type SM, hand-pushed**
- **type CM, mechanically-operated chain**
- **type EM, electrically-operated**

They run on the lower flange of the beam and are adjustable for flange width. They are made of pressed steel fitted with stirrups to prevent drop or derailling [RES. 4.1.2.2 - Machinery Directive], and equipped with shock absorbing buffers. The trolleys are fitted with pressed steel machined wheels rotating on permanently lubricated ball bearings.

Limit switches These switches limit the horizontal travel of the electrically-operated trolley on the beam [RES. 4.1.2.6 a - Machinery Directive].

Towing arm The towing arm, which is the connecting element between the trolley and the power supply is available for all types of trolleys of the DMT series.

It is adjustable in all directions and provides for power supply cable towing as needed to ensure that the cable is not torn.

RULES AND CERTIFICATION

design and manufacture



DMK electric chain hoists and trolleys are designed and produced following the “Essential Safety Requirements” of Enclosure I of the Community Directive 98/37/EC ex 89/392/EEC and successive amendments 91/368/EEC, 93/44/EEC and 93/68/EEC, denominated Machinery Directive, transposed into Italian legislation with DPR N° 459 of 24.07.96.

Regarding what was stated in Enclosure II of the Directive 98/37/EC, the hoist can be put on the market in the following ways:

a) **Complete**, or capable of functioning independently, **having the CE Marque** and the **EC Declaration of Conformity - Enclosure II A.**

b) **Incomplete** as destined to be incorporated in another machine and/or to be completed by the Customer.

In this case, in accordance with **Article 4 - paragraph 2** of the **Directive 98/37/EC**, the hoist does not carry **the CE Marque** and is supplied with the **Declaration of the Manufacturer - Enclosure II B.**

Furthermore DMK hoists and related trolleys conform to the following Directives:

- **The Low Voltage Directive** (in Italian Direttiva Bassa Tensione DBT) **73/23/EEC**, transposed into Italian legislation with **Law No 791/77** modified with **D.Lgs No 626/96** and with **D.Lgs. No 277/97.**
- **The Electromagnetic Compatibility Directive (EMC) 89/336/EEC** transposed into Italian legislation with **D.Lgs. No 476/92** modified with **D.Lgs. N° 615/96.**

DMK electric chain hoists and trolleys are available, on request, with homologation CSA with **ANSI/UL** extension.

Reference frame

The design and manufacture of DMK electric chain hoists conform to the following rules and technical regulations:

- EN 292 parts: 1a - 2a “Safety of the machinery”.
- EN 60204 - 1: “Safety of the electrical equipment of the machines - General rules”.
- EN 60204 - 32: “Safety of the electrical equipment

of lifting machines”.

- EN 60439 - 1: “Low voltage controls equipment”.
- EN 60529: “IP enclosure”.
- ISO 4301: “Classification of lifting equipment”.
- UNI 7670: “Calculation of the mechanisms of the lifting equipments”.
- DIN 15401: “Choice of the lifting hooks”.
- FEM 9.511/86 “Mechanisms classification”

- FEM 9.671/88 “Quality of chains, criteria of choice and technical requirements”
- FEM 9.761/93: “Overload devices”.
- FEM 9.683/95: “Choice of the lifting and traverse motors”.
- FEM 9.755/93: “Periods of safe work”.
- FEM 9.941/95: “Control symbols”.