

Heavy Duty Type



Lifts Lighting Equipment: up to 30kg, 15/20m high
up to 50kg, 10m high

The Heavy Duty Type has been designed for use with heavy luminaires such as chandeliers, lighting rigs and clusters in ballrooms, conference centres, religious buildings, stage and theatre where extended lifting distances are required.



PSI-20/30

PDI-35/50

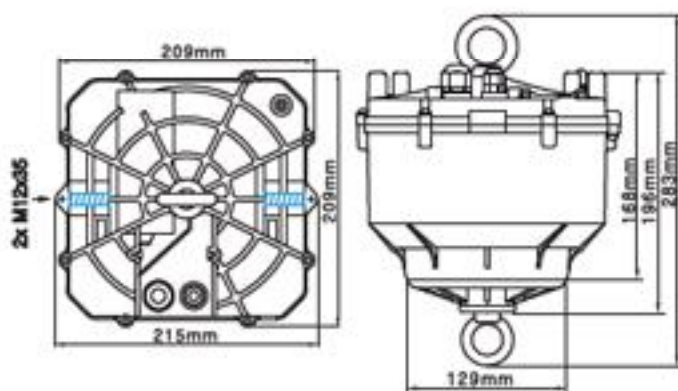

Heavy Duty Type Type	PSI-20	PSI-30	PDI-35	PDI-50
Unit net weight /with packaging	8.7/9.9 kg	8.7/9.9 kg	8.7/9.9 kg	9.5/10.7 kg
Lifting capacity	7-20 kg	12-30 kg	15-35 kg	15-50 kg
Lowering distance	15/20 m	15/20 m	10 m	10 m
Temperature range	-15 bis +60 °C	-15 bis +60 °C	-15 bis +60 °C	-15 bis +60 °C
Protection category/class	IP 54/ II	IP 54/ II	IP 54/ II	IP 54/ II
Lifting speed	5.4 m/min	5.4 m/min	2.7 m/min	2.7 m/min
Suspension wires: number/diameter	1/2.4 mm	1/2.4 mm	2/2 mm	2/2 mm
Capacity	16 A	16 A	16 A	16 A
Operating voltage	230V AC, 50 Hz/1.3 A	230 VAC, 50 Hz/1 A	230 VAC, 50 Hz/1.3 A	230 VAC, 50 Hz/1 A
Standby current	0.1 A	0.15 A	0.1 A	0.15 A
Type of electric motor	AC Motor	BLDC Motor	AC Motor	BLDC Motor

* These lifts are capable for Synchro-use. See pages 14-15.

www.dale-lifting.co.uk 0161 223 1990